



HEAT RECOVERY SYSTEMS



CONTENTS

1. **Introduction**
2. **Marine Applications**
3. **Industrial Applications**
4. **Power Plant Applications**
5. **Exhaust Gas Boiler Sectional View**
6. **The Clayton Exhaust Gas Boiler**
7. **Boiler Configurations**
8. **Features And Advantages**
9. **Coil Corrosion Protection**
10. **The Clayton R-System**
11. **The Clayton Lamont System**
12. **The Clayton E-System**
13. **The Clayton Hot Water System**
14. **Summary Of Applications**
15. **Exhaust Gas Temperatures**
16. **Output Control**
17. **Boiler Selection Questionnaire**
18. **Reference List**

1. INTRODUCTION

Clayton Steam Systems have manufactured steam generators for over 70 years and Clayton Heat Recovery Boiler systems have been produced for more than 40 years - ensuring energy savings and heat recovery - worldwide.

Clayton exhaust gas heat recovery systems are ideal for use in marine, industrial and power plant applications.

THE IDEAL SOLUTION FOR ALL STEAM APPLICATIONS

Clayton Steam Generators, Exhaust Gas Boilers and Combi Boilers are suitable for all marine and land based steam applications and over 20,000 units have been supplied.

Clayton have manufacturing plants in USA, Mexico and Europe as well as a global distributor network and worldwide service capabilities.

Clayton Exhaust Gas Boilers are suitable for all shipboard, offshore and co-generation applications.



STEAM GENERATOR



EXHAUST GAS BOILER

2. MARINE APPLICATIONS

Clayton Exhaust Gas Boilers are used on dry cargo ships, chemical carriers, passenger ferries, reefer vessels, gas tankers, drilling rigs, fish processing vessels, FPSO's, Navy and sea defence ships and a wide range of the other vessels. A typical installation usually consists of a combination of one or more fired steam generators and an exhaust gas steam generator or boiler.

Clayton Industries provide world-wide spare parts availability and service from a network of Clayton owned companies and trained distributors.

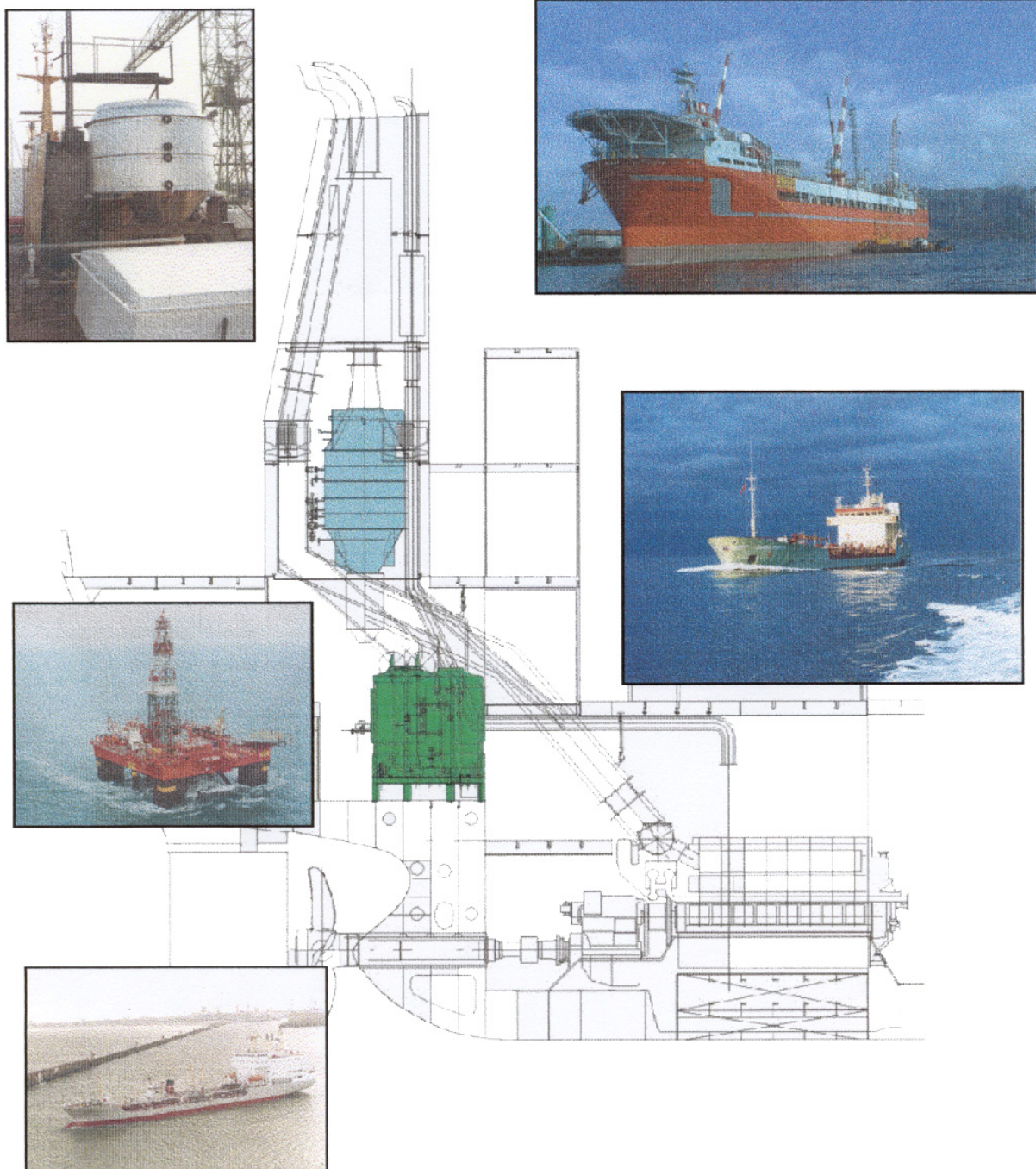

3. INDUSTRIAL APPLICATIONS

In industrial application, from a practical standpoint, all of the heat in exhaust gases above 200 °C (390 °F) can be recovered and converted into steam or hot water.

Steam can be generated using the heat in waste gas from ovens, incinerators and many other processes.



4. POWERPLANT APPLICATIONS

STEAM PRODUCED FOR INTERNAL USE

- Fuel Heating
- Auxiliary steam

CO-GENERATION:

- Maximum generation of steam for process use



5. EXHAUST GAS BOILER SECTIONAL VIEW

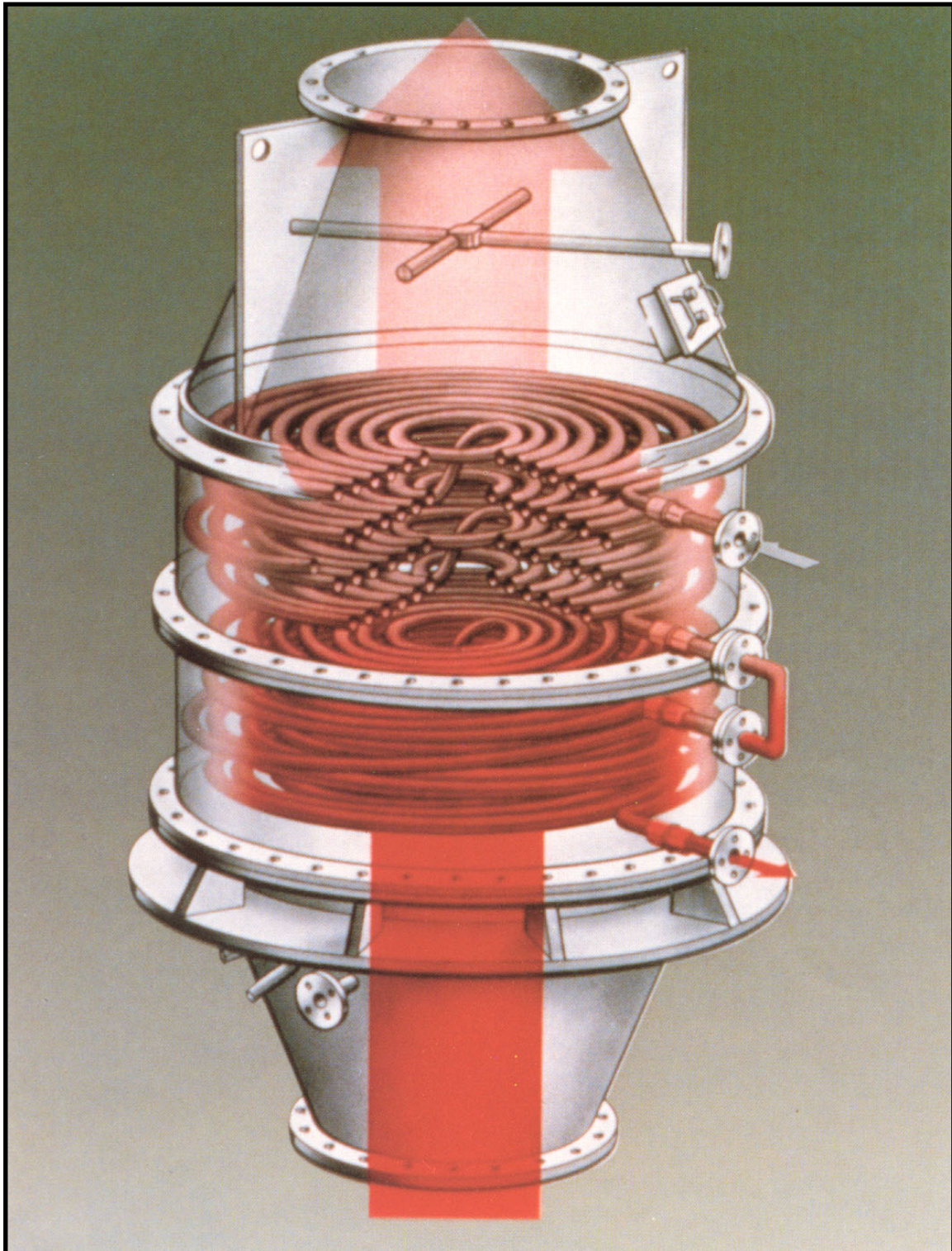

CLAYTON EXHAUST GAS BOILER / SECTIONAL VIEW

6. THE CLAYTON EXHAUST GAS BOILER

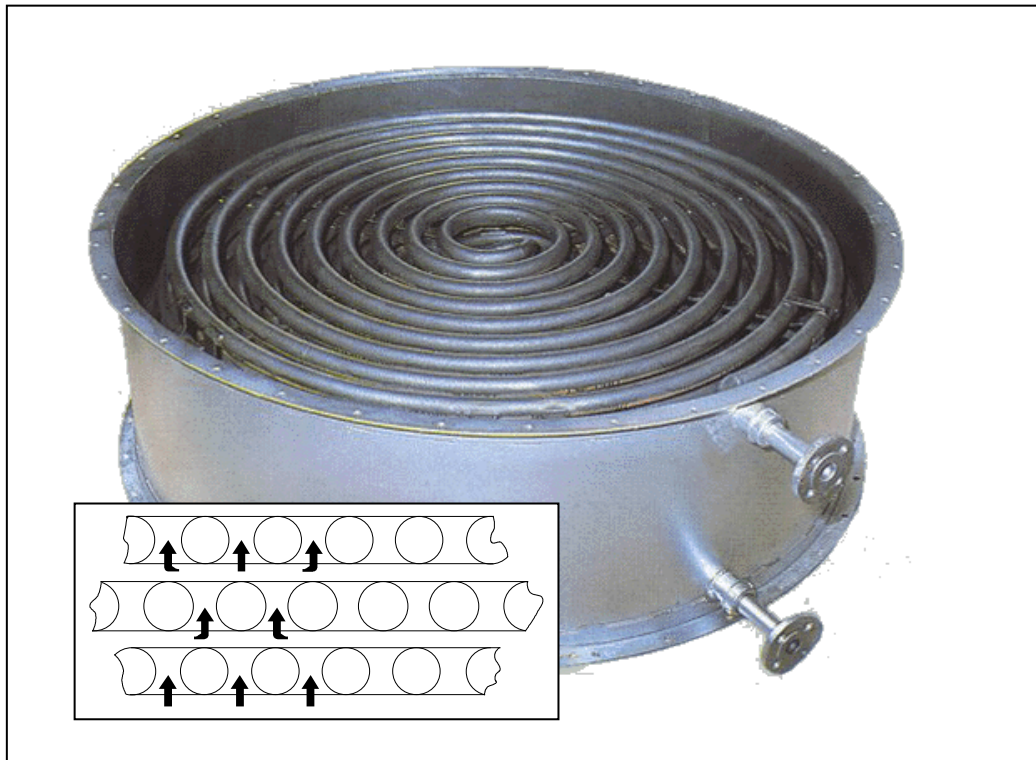

General Description

The CLAYTON Exhaust Gas Boiler is a single coil, water tube boiler with forced circulation - of similar construction to the world-famous Clayton Steam Generator.

The boiler consists of a number of cylindrical sections. Each of these sections contain spirally wound coil layers (so-called pancakes), made from plain steel tube - ST.37.8, to DIN 17177. The normal test pressure of the tube is 40 bar and the coil is stress-relieved at 600 °C.

The number of sections used is dependant on the heat output requirements of the boiler.

The staggered (zigzag) configuration of the pancakes, one above the other, improves heat transfer from the exhaust gases to the tubes.

Any expansion of each pancake due to localised temperatures can occur independently of each other.

A section consists of 4 or 6 pancakes mounted in a gas tight cylindrical shell. Flanges on the top and bottom of the shells are provided for ease of mounting, one on top of the other. Bolts, nuts and packing rings are included in the Clayton scope of supply.

The sections are factory assembled and the external interconnections on the steam and water side are included in the Clayton scope of supply.

The spacing between tubes vary with each Exhaust Gas Boiler model and the free gas section determines the gas side resistance.

7. BOILER CONFIGURATIONS

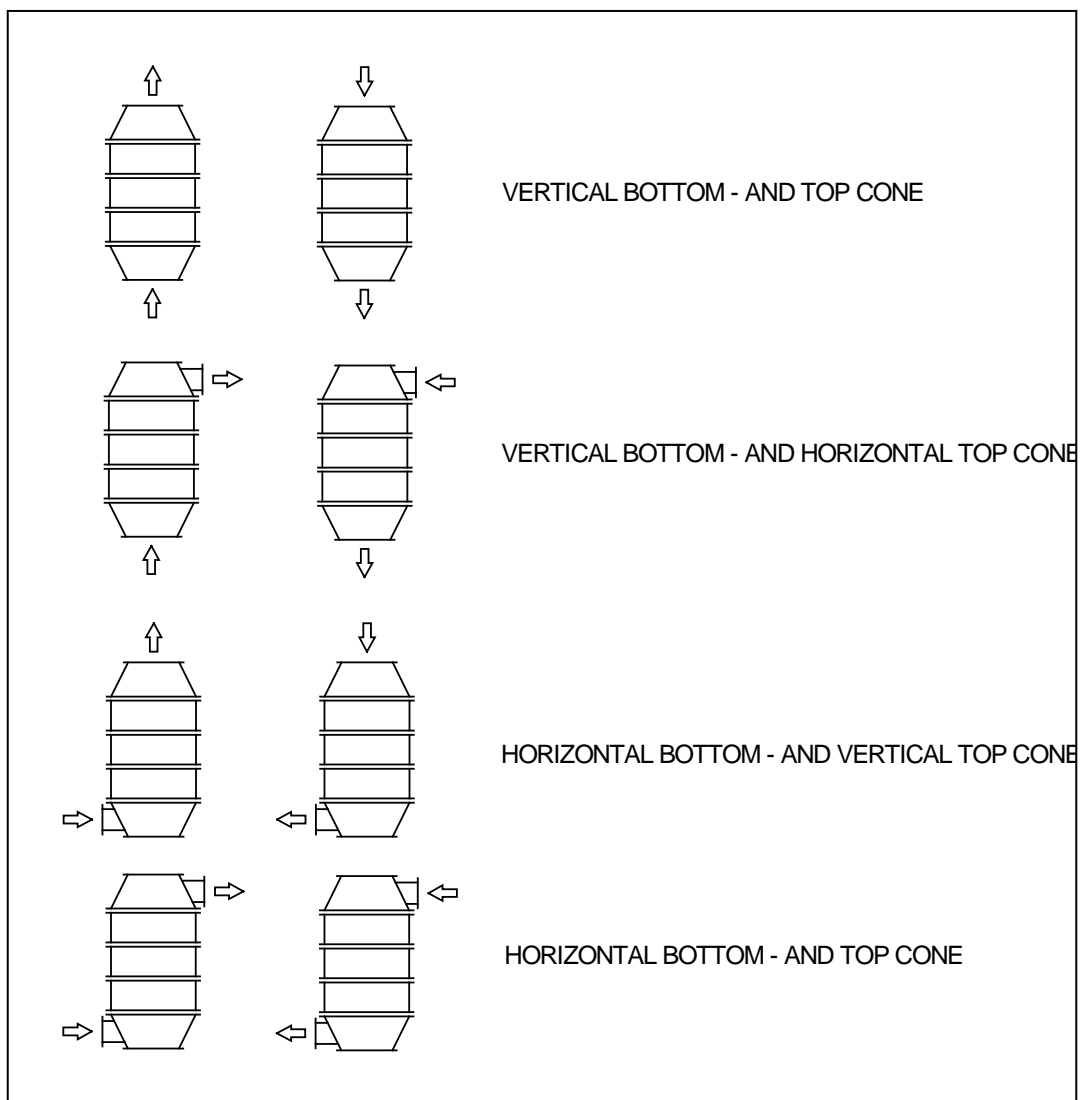

Installation Options

Because of the design concept of the Clayton Exhaust Gas Boiler and the small size and weight, a number of installation options are possible. The boiler can be constructed in several different configurations to fit into exhaust gas ductwork to suit the client's requirements.

The above illustrations show the gas flow path options which are usually available.

8. FEATURES AND ADVANTAGES

FEATURES	ADVANTAGES
COUNTER FLOW	<ul style="list-style-type: none"> - COMPACT DESIGN - MAXIMUM EFFICIENCY - LOW WATER CONTENT - RAPID START UP
PLAIN TUBES	<ul style="list-style-type: none"> - MINIMUM FIRE RISK - EASY TO CLEAN - LOW SURFACE TEMPERATURE - LOW EXHAUST GAS PRESSURE DROP
STAGGERED TUBE CONFIGURATION	<ul style="list-style-type: none"> - HIGH HEAT TRANSFER - MINIMUM SOOT BUILD-UP
FORCED CIRCULATION	<ul style="list-style-type: none"> - NO WATER LEVEL INSIDE THE BOILER - FREE CHOICE OF DIRECTION OF BOTH GAS AND WATER - HIGH HEAT TRANSFER
SPIRAL WOUND TUBES	<ul style="list-style-type: none"> - FLEXIBLE CONSTRUCTION - DRY RUNNING POSSIBLE UP TO 450°C EXHAUST GAS TEMPERATURE
STANDARD SECTIONS	<ul style="list-style-type: none"> - AVAILABILITY - BY-PASS POSSIBLE - APPROVED CONSTRUCTION FOR ALL INSPECTORATES

9. COIL CORROSION PROTECTION

Exhaust gases contain substances which, under certain conditions, can condense on the outside of the boiler tube and lead to external pipe deterioration. Corrosion is caused by sulphur and water in the exhaust gas.

Obviously, a fuel which has a high sulphur content presents the highest risk of sulphuric acid corrosion. Water can also cause external pipe corrosion if condensation occurs. The most appropriate way of avoiding harmful effects in this case is to maintain the tube wall temperature above a specific minimum value, depending on the type of fuel being used. It should be noted that it is the tube wall temperature which affects the formation of condensation and not the temperature of the exhaust gas - even although this may be well above the dewpoint of the gases.

The curve shown below illustrates the corrosion rate of steel pipe caused by fuel containing sulphur. It can be seen that the corrosion rate caused by sulphuric acid is at a minimum when the wall temperature is above 130°C.

In general, water condensation will occur on surfaces where the temperature is below 70°C. Exhaust gas condensation is a complex process and several factors influence the dewpoint of gases.

The Clayton systems as described on the following pages are designed so that the tube wall temperature is maintained within safe limits for the type of fuel being used in the engine.

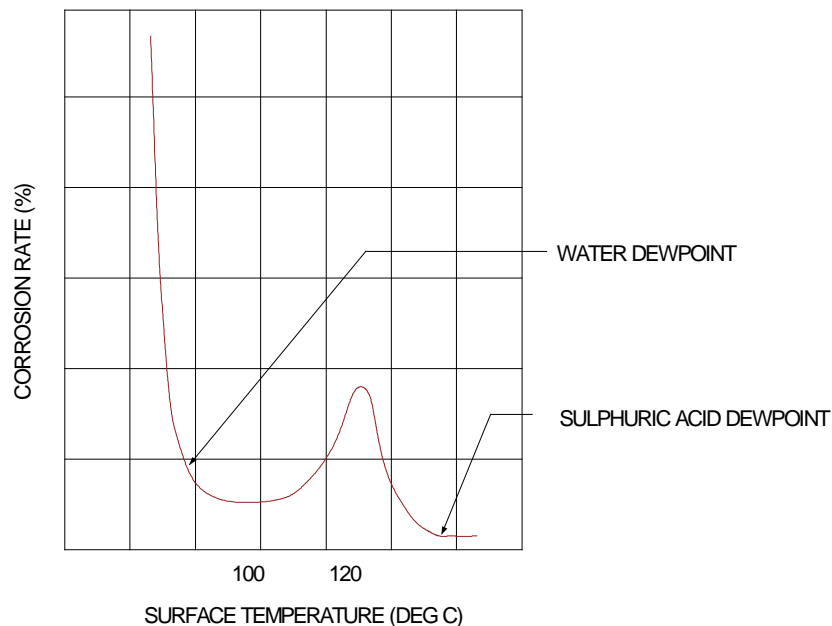

10. THE CLAYTON R-SYSTEM

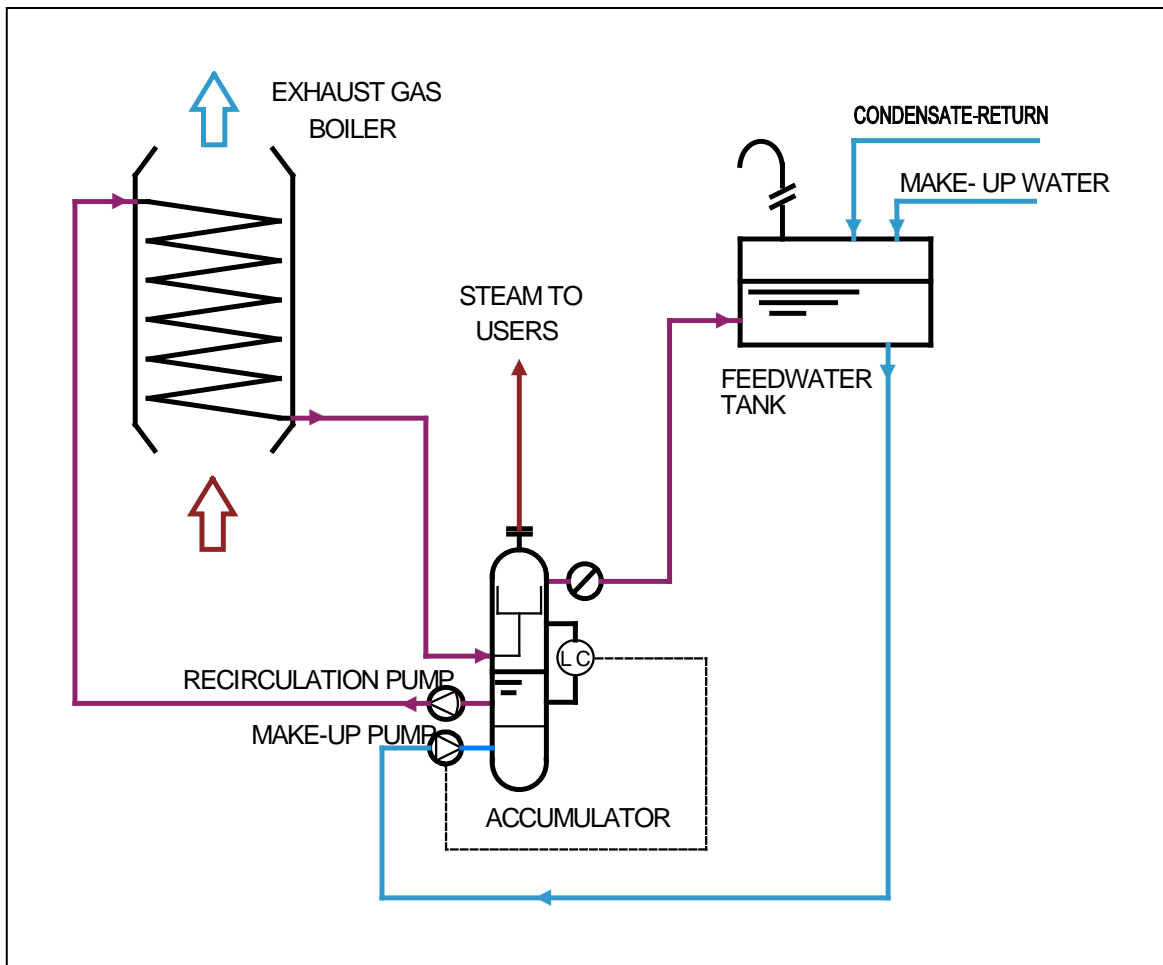

System Description

In the Clayton R-System, feedwater is pumped from a feedwater tank to an accumulator/separators which is a pressurised vessel with controlled water level. Water is then pumped to the boiler by means of a Clayton waterpump. The accumulator preheats the water supply to the boiler and separates the steam and water mixture from the boiler discharge. The amount of water recirculated is approximately twice the quantity of steam produced by the boiler at full load.

Feedwater Tank

The feedwater tank (or 'hotwell') is used to blend fresh make-up water with return condensate from the installation, and the content is preheated by steam injection to naturally drive out oxygen and non-condensable gases. The water preheat temperature is controlled at 95°C. Water

treatment chemicals are also dosed into this tank. Alternatively a pressurised deaerator can be used for the feedwater supply.

Accumulator

The accumulator/separators uses a system of internal fixed vanes to produce efficient separation of the steam/water mixture from the boiler. The separated water, which is at steam saturation temperature, mixes with the incoming feed water in the accumulator to ensure that the temperature of the water supplied to the boiler is sufficiently high above the acid dewpoint of the exhaust gases to protect against corrosion.

The Clayton R-system is of a compact design and components such as the accumulator and pump modules can be pre-assembled on skids. This system can also be used for multiple boiler installations of up to 4 boilers.

11. THE CLAYTON LAMONT SYSTEM

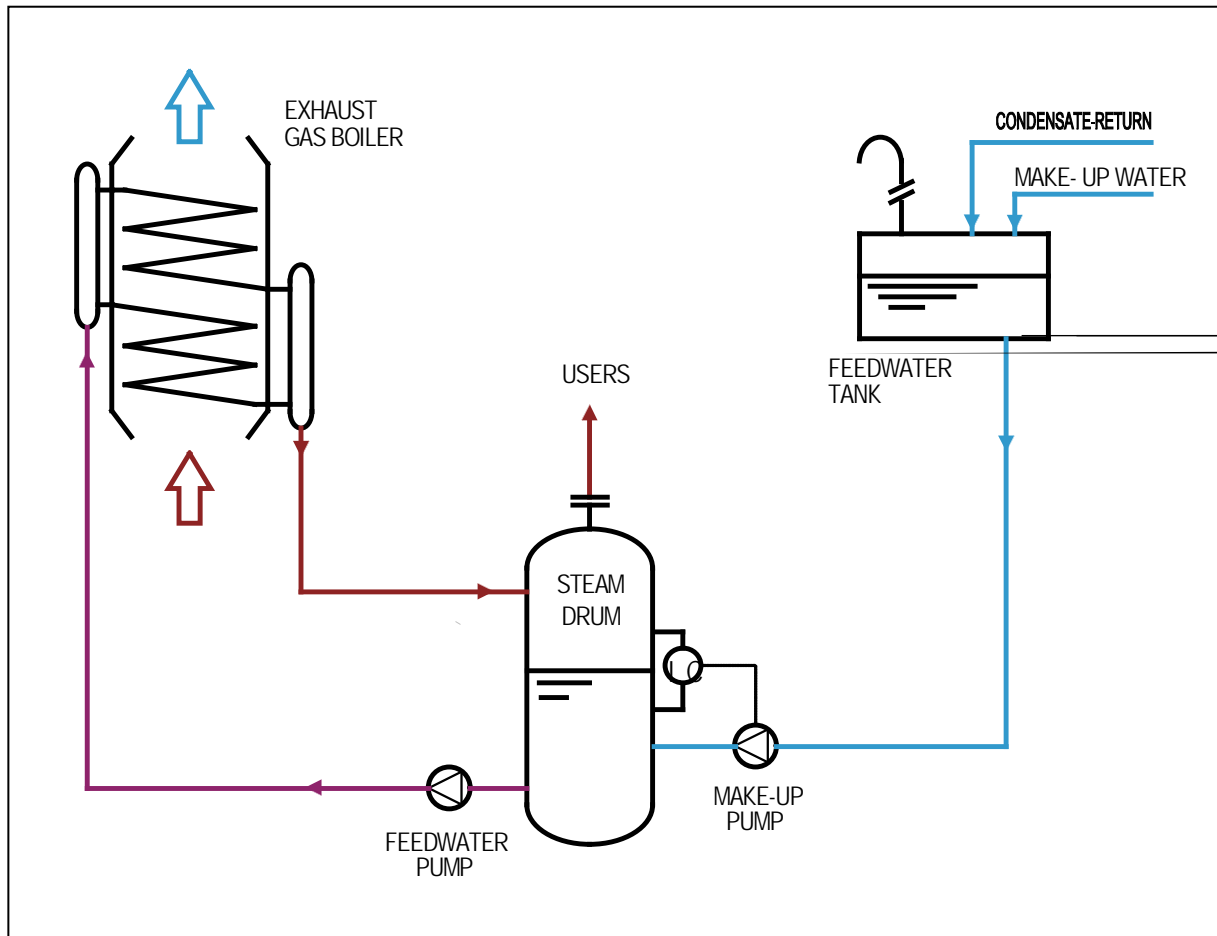

System Description.

In the Lamont System, water from a feedwater tank or deaerator is pumped to a vertical or horizontal steam drum. The steam drum is half full of water and has sufficient capacity to cope with the dynamic behavior of the system. A centrifugal pump passes water from the drum and circulates it over the Exhaust Gas Boiler. The recirculation rate in a Lamont system is much higher than in the Clayton R-system. This means that the water in the steam drum is virtually at steam saturation temperature and this provides extremely good protection against the effects of sulphur in the exhaust gases.

The water/steam mixture from the boiler outlet returns to the steam drum, where separation

between water and steam takes place. The steam exits the steam drum from the top outlet.

Boiler Configuration

In the Lamont system, the boiler tube layers are arranged in parallel, so that the flow resistance on the water side is kept as low as possible to minimise the power consumption of the circulating pumps. Inlet and outlet headers connect all sections on the water/steam side.

Application

This system is used for larger power or cogeneration plants, or where a multiple boiler system is installed.

12. THE CLAYTON E-SYSTEM

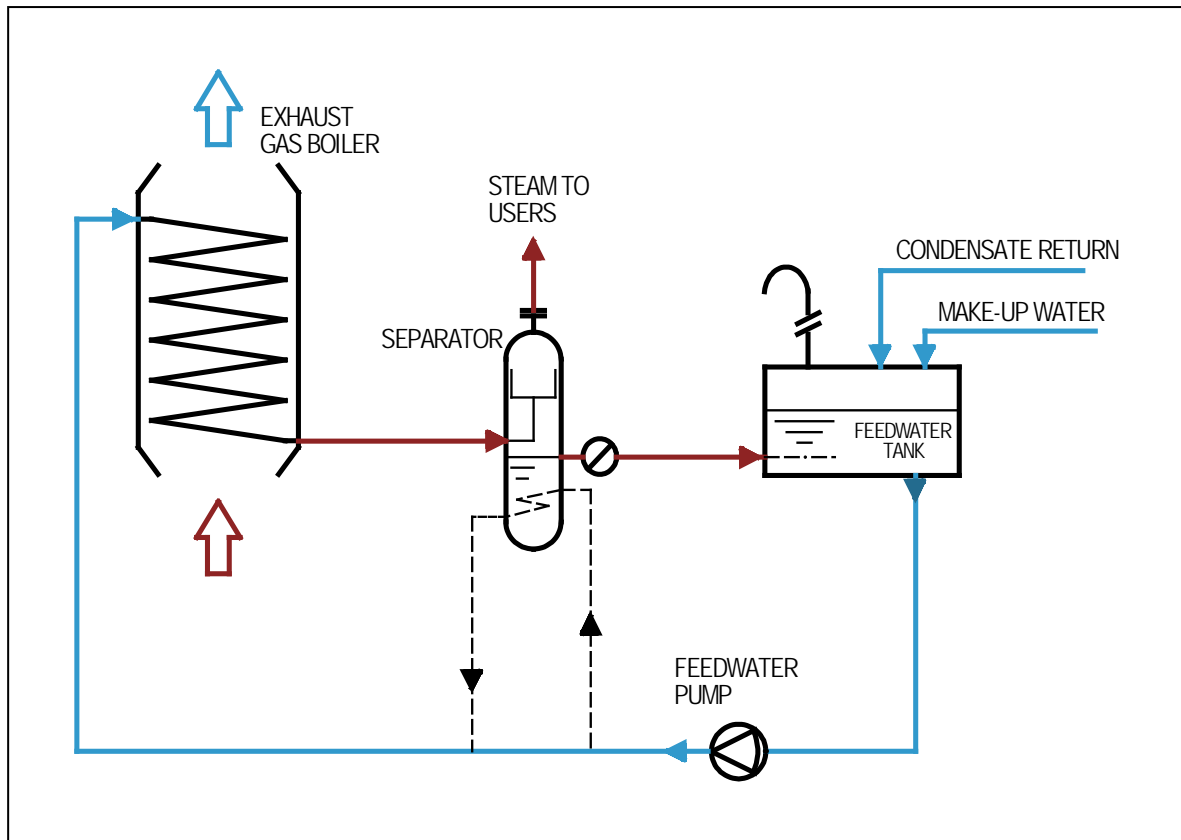

System Description

In the Clayton E-System water is pumped from a feedwater tank through the heating coil of the Exhaust Gas Boiler by means of a Clayton waterpump. A mixture of water and steam flows from the outlet of the Exhaust Gas Boiler and is separated in a centrifugal separator. Dry steam leaves the separator from the top outlet. A steam trap is mounted on the side of the separator which returns the separated hot water to the feedwater tank. In the feedwater tank the water and flash steam are mixed below the water level with fresh incoming water and condensate.

Feedwater Tank

The feedwater tank (or 'hotwell') is used to blend fresh make-up water with return condensate from the installation, and the content is preheated by steam injection to naturally drive out oxygen and non-condensable gases. The water preheat temperature is controlled at 95°C. Water treatment chemicals are also dosed into this tank. Alternatively a pressurised deaerator can be used for the feedwater supply.

The Clayton Pump

The Clayton pump is a positive displacement pump of an entirely closed construction and does not require seals or stuffing boxes. The use of a positive displacement pump in the system ensures that a predetermined water quantity flows through the boiler. This quantity includes an excess amount to prevent overheated and scaling of the boiler tube. The excess water quantity in the Clayton E-System is approximately 20% of the steam production.

Applications

This system is suitable for use on exhaust gases from gas fired or diesel oil fired engines with outputs in the range of around 250 kW to 2 MW. The E-system is used where the heat consumption is stable and is at a sufficiently high level. Thermal balance for the feedwater tank must be calculated for partial load conditions, because the condensate returned from the separator can cause preheating of the water in the feedwater tank. For systems where partial loads (engine output and/or steam demand) occur frequently, the Clayton R-system or Lamont systems are recommended.

13. THE CLAYTON HOT WATER SYSTEM

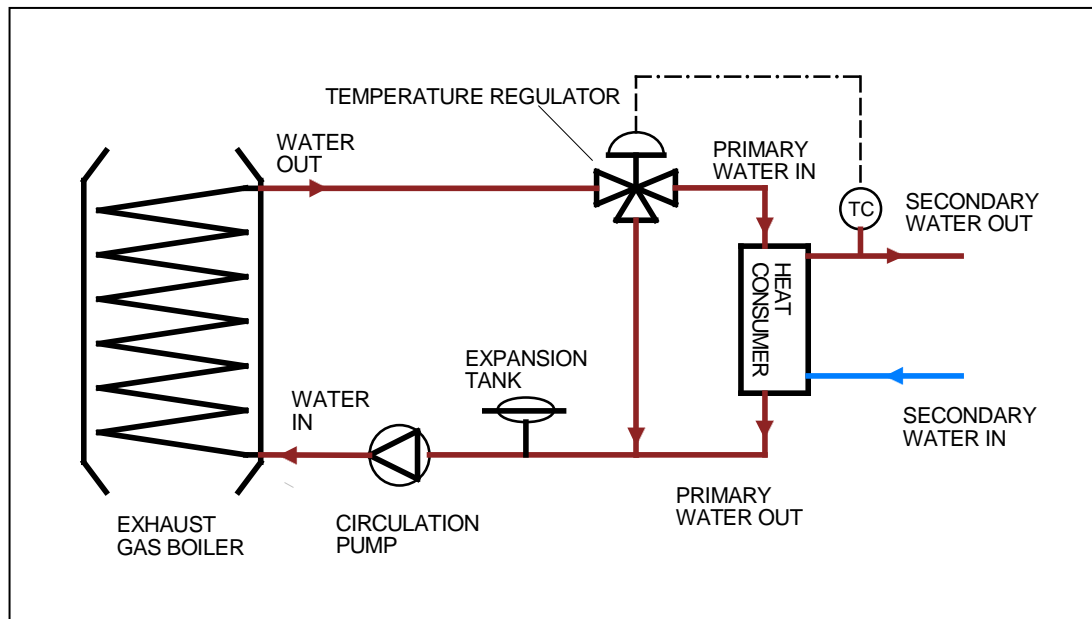

The Clayton Exhaust Gas Boiler can also be used in a closed loop system to generate hot water. The water temperature is dependant on the type of fuel being used.

The minimum temperature of water entering the boiler is generally as below:

130°C	Heavy Fuel Oils
95°C	Diesel Fuel Oils
70°C	Gases from Combustion of Natural Gas - Clean Gas
95°C	Gases from Combustion of Natural Gas Combustion, from a Diesel Engine or Spark Ignited Engine and Gases Containing Traces of Soot and Unburnt Lubricating Oil.

The primary loop contains a circulating pump, expansion vessel and heat exchanger(s) as well as control valves.

14. SUMMARY OF APPLICATIONS

HEAT SOURCE	TYPE	OUTPUT	EXHAUST GAS QUANTITY APPROX. kg/hr	EXHAUST GAS TEMP °C	CLAYTON EXHAUST GAS BOILER TYPE	CLAYTON FLOW SYSTEM
Diesel Engine	Medium Speed Diesel Oil & Heavy Oil	2 to 15 MW	10,000 to 110,000**	300 to 400	Standard Sections	Lamont & R
	Slow Speed HFO	Up to 10 MW	Up to 110,000	250	Standard Sections	Lamont
	Medium Speed	Below 2 MW	Up to 10,000			
	Diesel Oil			Up to 350	Standard Sections	E***
	Gas			Up to 550	ECO Sections	E***
Gas Fired Engine	Natural Gas or Biogas	Below 2 MW	Up to 10,000	Up to 550	ECO Sections	E***
		Up to 10 MW	Up to 110,000	Up to 550	Standard Sections	Lamont & R
Gas Turbine	Natural Gas	Up to 2 MW*	Up to 45,000	540	Standard Sections	Lamont
Industrial Ovens & Other Heat Sources			Up to 15,000 at 1000°C	Up to 1200	Heating Coil Fired Models	E or R

*On gas turbines with outputs higher than 2MW, twin exhaust boilers can be used.

**Exhaust gas quantity may be reduced if maximum heat recovery is required.

***R-System is used for multiple units.

15. EXHAUST GAS TEMPERATURES

High exhaust gas temperatures occur on applications where an Exhaust Gas Boiler is used for furnaces or industrial processes where the exhaust gases fed to the boiler are in excess of 450⁰C.

Temperatures up to 550⁰C

The concept of utilizing standard coil sections can generally be adopted where the maximum exhaust gas temperatures is 450⁰C. However special materials are available for construction of boiler shells which enable gas inlet temperatures of up to approximately 550⁰C to be accomodated.

Temperatures up to 1200⁰C

For higher temperatures the same concept is utilized as on the Clayton standard Steam Generator. The advantage of the coil construction on these units is that the shell of the boiler is cooled by a "waterwall" coil.

This heating coil type of boiler can handle temperatures of up to 1200⁰C - depending on the allowable flow resistance on the gas side.

16. OUTPUT CONTROL OF EXHAUST GAS BOILERS

Heat Capacity

The heat capacity of an Exhaust Gas Boiler is determined by the heat input - which is in turn determined by the engine load. Because heat production at high engine output is greater than the heat produced at low engine output, the steam produced from an Exhaust Gas Boiler will vary between certain limits.

A process which can use the steam produced from the Exhaust Gas Boiler will either be able to accept variations in heat output or there will be times when steam output outstrips steam demand of the process. Heat production and heat demand must be in balance and, during periods when this is not the case, some of the heat output must be either dissipated, or the heat supply to the boiler must be regulated.

There are two methods used to control the heat output of an Exhaust Gas Boiler

Dumpcooler

By using a dumpcooler the boiler constantly produces the maximum flow of steam. When the heat required is less than this maximum flow it will be diverted to the dumpcooler where steam will be condensed. This condensate is returned to the feedwater tank. The excess steam is therefore converted into good quality feedwater which can be passed back into the system.

The amount of steam or hot water which is dumped can be controlled from pressure or temperature sensors. Any increase will cause a valve to open at a predetermined set point so that the excess steam or water is diverted to the cooler.

This method of output control is simple and reliable. In addition the full flow of exhaust gas is maintained through the boiler which minimises the risk of soot accumulation and corrosion.

The dumpcooler is a heat exchanger, cooled by either:-

- Water: Seawater can be used on shipboard installations and cooling water from engine cooling circuits can be used in power plants.
- Air: Air can be used in power plants. In this case the air cooler for engine cooling can be adapted to also act as a condenser for the excess heat. Alternatively a separate air blast cooler can be installed to cool the excess heat from the Exhaust Gas Boiler.

Exhaust Gas By-Pass

Using a gas by-pass valve the exhaust gases are diverted either through the boiler or around it. The heat input can therefore be regulated to the demand for steam or hot water.

This method is more expensive to install and maintain and is more prone to failure due to the high temperatures involved.

17. BOILER SELECTION QUESTIONNAIRE

Boiler selection is based on exhaust gas flow, gas temperature and maximum allowable gas side pressure drop. The heating surface is calculated based on the required heat output of the boiler. The free space between tubes turns is determined by the boiler model and the gas

side pressure drop is dependant on the number of tube layers and hence the heating surface.

Computer programmes are used to choose the optimum boiler size which is derived from the operating parameters specified by the client.

The following information is requested so that the boiler and auxiliary equipment can be correctly selected

Engine (or turbine)

Make : Type :

Fuel

Diesel

Heavy Oil

Gas

Viscosity:

Spark Ignition

Composition:

Dual Fuel

Exhaust Gas Flow

Quantity : kg/hr or Normal M³/hr

Exhaust Gas Temperature

°C

Allowable Exhaust Gas Pressure Drop:

mmwg or Pa (Pa = 0.1mmwg)

For Steam Systems

Required Boiler Output (kW) : or Required Steam output (kg/hr)

Feedwater Temperature (°C) : (If temperature is not know 90°C will be assumed)

Steam Pressure : bar gauge : or bar absolute

For Hot Water Systems

Required Boiler Output (kW) :

Water Inlet Temperature (°C) :

Water Outlet Temperature (°C) :

Special Requirements:

.....

18. REFERENCE LIST

PARTIAL REFERENCE LIST OF CLAYTON EXHAUST GAS BOILERS. HEAT RECOVERY BOILERS ON LAND INSTALLATIONS AND COGENERATION PLANTS.

A selection of customers using Clayton heat recovery boilers world-wide.

ABB

ALSTHOM

BAYER

BEKAERT

HOECHST

DEUTZ-MWM

MAN

CATERPILLAR MAK

CAT ASIA

WARTSILA NSD

ROLLS ROYCE

NIIGATA DIESEL

C.K.D. DIESEL

SONMEZ TEXTILE

BORUSAN TURKEY

POWER BARGES

Clayton reserves the right to make alterations to designs and equipment without notice and the information contained herein is intended as a general guide only.